



**H2othouse Greenhouses**  
Conservatory Plans, Links and Resources

**Plans   Supplies   Kits   Books   Links   Orders   ► More!**

Victorian Conservatory  
Booklet & BOM

# How to build your own greenhouse in the grand style of turn of the century conservatories



Revised August 30, 1998

By Joe Zeeben; BSME, MBA

## TABLE OF CONTENTS:

### I. Getting Started \*

- B.O.M. Bill of Material \*
- Locating the Greenhouse \*
- Sunlight \*
- Modifying the Design to Fit your Needs \*
- Climate \*
- Local Building Codes\*
- Attaching to an Existing Building \*
- Using Different Materials \*

### 2. Pouring the Foundation \*

- Layout \*
- Forms: Framing The Foundation \*
- Roughing in the Plumbing & Electrical \*
- The Pour \*

### 3. Framing \*

- The Main Room \*
- The Side Rooms \*
- The Mid Joists \*
- The Cupola \*
- The Brick \*
- The Lower Sill / Vertical Dividers / Horizontal Dividers. \*

### 4. Electrical / Plumbing / Glass / Lighting / HVAC \*

- Electrical \*
- Plumbing \*
- Painting \*
- Glassing the Roof \*
- Attaching the Spire\*
- Windows Galore \*
- Entry Door \*
- HVAC \*

## 5. Furnishings / Growing Hints / Resources \*

- Accessories \*
- Growing Hints \*
- Resources \*
- Getting Started

This is a big project, especially if you work full time and, depending on how it is scheduled, can drag on for years. We stretched ours over two years and we still haven't completed the accessories or the air distribution system. Set realistic expectations, give yourself plenty of time, and watch it grow!

Before you spend any more money, use the checklist below:

1. Check local building codes, determine if there are any deed restrictions, look-up any set back requirements and easement regulations.
2. Layout the whole yard and the house. This conservatory will probably become the dominating structure in your yard.
3. Budget your time and money. The total cost should vary between \$8,000 and \$20,000 depending on choices you make early on – single or double pane, treated wood or cypress, salvaged materials or new, build yourself or hire some one. We built the foundation and the main room the first year, wrapped it in plastic, and used a propane heater to keep the plants from freezing. The second summer, we completed it.
4. Provide the Bill of Material to your local lumber yard, glass contractor, or general contractor and get an actual estimate. If you're doing the work yourself, you'll need probably 8 long weeks with a helper to do all the work.

Approximate Material Price(does not include labor except glass):

Foundation	\$1,500
Framing	\$1,500
Brick	\$600
Trim	\$700
Windows (Single Pane) installed	\$6,000
Electrical and Plumbing	\$900
Total	\$10,200

B.O.M. Bill of Material

BOM Table 1 of 4. Available in Microsoft Excel upon request.

Item #	Quantity	Unit of meas. or x = Pressure Treated	Size/Description	Est. Price Each	Total Est. Cost
<u>Foundation</u>					
	7	x	2 x 12 x 16' (Re-use for Accessories and scaffolding)	\$20.00	\$140.00
	66		2 x 4 x 30" Stakes (every 2')	\$1.00	\$66.00
	10	lbs	8d Duplex nails	\$4.00	\$40.00
	36		1 x 2 Stakes and Angel braces (every 4' excluding inside corners)	\$0.10	\$3.60
	20		1/2 x 20' Rebar	\$5.00	\$100.00
	1	100' Roll	6 x 6 Welded Wire Mesh	\$50.00	\$50.00
	18		1/2 x 12 Anchor Bolts with flat washer and nut	\$2.00	\$36.00
	5	*Cu. yds	Clay dirt or Crushed Rock (*approx.)	\$20.00	\$100.00
	10	*Cu. yds	Concrete (*Approximate)	\$55.00	\$550.00
	700	Sq. ft.	6 mil polyethylene	\$0.05	\$35.00
				Total	\$1,120.60

BOM Table 2 of 4. Available in Microsoft Excel upon request.

Item #	Quantity	Unit of meas. or x = Pressure Treated	Size/Description	Est. Price Each	Total Est. Cost
<u>Framing</u>					
Post_A	12	x ea	6 x 6 x 10'	\$20.00	\$240.00
Post_B	6	x ea	6 x 6 x 8'	\$17.00	\$102.00
TieRod_A	4	ea	1/2 x 1-1/2 Galvanized Flat Bar 5/8" hole centered 1" from end..6'9"long..	\$50.00	\$200.00
TieRod_B	10	ea	1/4 x 1-1/2 Galvanized Flat bar w/ 5/8" dia.hole 1" from end. 27.5" long	\$10.00	\$100.00

TopPlate_A	4	x ea	6 x 6 x 16'	\$35.00	\$140.00
TopPlate_B	6	x ea	4 x 6 x 8'	\$15.00	\$90.00
TopPlate_C	3	x ea	4 x 6 x 8'	\$15.00	\$45.00
MidPlate_A	8	x ea	4 x 6 x 3'-6.5"	\$5.00	\$40.00
WinSill_A	3	x ea	2 x 8 x 7'1"	\$8.00	\$24.00
WinSill_B	6	x ea	2x8x7'-6.5; (3) Opposite	\$8.00	\$48.00
WinSill_C	8	x ea	2 x 8 x 3'6.5"	\$4.00	\$32.00
Win_Int	8	x ea	2 x 6 x 5'	\$3.00	\$24.00
Ridge_Low	3	x ea	2 x 6 x 8'	\$5.00	\$15.00
Ridge_Support	3	x ea	2 x 6 x 1'2-7/8"	\$1.00	\$3.00
Joist_L_A	24	x ea	2 x 6 x 4'4.5"	\$3.00	\$72.00
Joist_L_B	6	x ea	2 x 6 x 4'4.5"	\$3.00	\$18.00
Joist_M_A	20	x ea	2 x 6 x 4'7-9/16	\$3.00	\$60.00
Joist_M_B	4	x ea	2 x 6 x 6'1-7/16	\$3.00	\$12.00
Cup_Base	4	x ea	2 x 8 x 7'10.5	\$8.00	\$32.00
Cup_Sill	4	x ea	2 x 8 x 8'4"	\$8.00	\$32.00
Cup_post	4	x ea	6 x 6 x 1'8.5'	\$4.00	\$16.00
Cup_int	4	x ea	2 x 6 x 1'8.5	\$1.00	\$4.00
Cup_TopPlate	4	x ea	4 x 6 x 8'	\$15.00	\$60.00
Cup_Joist_A	4	x ea	2 x 6 x 4'4.375	\$3.00	\$12.00
Cup_Joist_B	4	x ea	2 x 6 x 5'10.25	\$4.00	\$16.00
Cup_key	1	x ea	6 x 6 x ~8"	\$2.00	\$2.00
Lag screws	8	ea	1/2 x 12" galv. lag screws with	\$2.00	\$16.00
Lag screws	28	ea	1/2 x 8" galv. Lag screws	\$1.50	\$42.00
Lag screws	8	ea	1/2 x 5" galv. Lag screws	\$1.25	\$10.00
Lag screws	20	ea	1/2 x 3" galv. Lag screws	\$1.00	\$20.00
				TOTAL	\$1,497.00

BOM Table 3 of 4

		<b>Unit of</b>		
--	--	----------------	--	--

Item #	Quantity	meas. or x = Pressur e Treated	Size/Description	Est. Price Each	Total Est. Cost
Brick	1500	ea	Actual number may vary depending	\$0.28	\$412.50
	1		on size of brick. Mortar Cement & Sa	\$100.00	\$100.00
				<b>Total</b>	<b>\$512.50</b>
<u>Trim Carpentry</u>					
Eave_L	6	x	(1/2) 2 x 4 x 10 ripped down the middl	\$2.50	\$15.00
Eave_M	6	x	(1/2) 2 x 4 x 10 ripped down the middl	\$2.50	\$15.00
Eave_M_B	1	x	(1/2) 2 x 4 x 10 ripped down the middl	\$2.50	\$2.50
Eave_T	4	x	(1/2) 2 x 4 x 10 ripped down the middl	\$2.50	\$10.00
Doors	2	Exterior	3260 single light French Door	\$125.00	\$250.00
Door_Fr_A	2	Fir	2 x 4 x ?	\$10.00	\$20.00
Door_Fr_B	2	Fir	2 x 4 x ?	\$10.00	\$20.00
Door_Fr_C	2	Fir	2 x 4 x ?	\$10.00	\$20.00
Door_Sill	1	x		\$5.00	\$5.00
Rake	6	x	2 x 8 x 6'	\$6.00	\$36.00
Ridge_Block_L	16	x	1/2 2x4x approx. 22.5" (varies)	\$0.50	\$8.00
Ridge_Block_M	24	x	1/2 2x4x approx. 22.5" (varies)	\$0.50	\$12.00
				<b>Total</b>	<b>\$413.50</b>
<u>Electrical</u>					
Supply_line	1	ea	Size depends on distance/consult cod	\$200.00	\$200.00
Breaker_Box	1	ea	100 amp with 4 breakers.	\$100.00	\$100.00
Breakers	4	ea	20 AMP GFCI Breakers.	\$30.00	\$120.00
Wire	100	ft	12 AWG with Ground, Underground	\$0.80	\$80.00
Int_Light	10	ea	Exterior flood lights	\$15.00	\$150.00
Fan	1	ea	Outdoor Rated Fan	\$100.00	\$100.00
Recepticals	9	ea	Outdoor Rated Recepticals	\$10.00	\$90.00
Ext_Light	2	ea	Exterior Lantern	\$15.00	\$30.00
Switch	3	ea	Outdoor Rated Switches	\$10.00	\$30.00
				<b>Total</b>	<b>\$900.00</b>





Windows			
Win_Large_D	2	ea	6'11.5x41.25 Glass for Large Back Wall Windows
Win_Sm_B	8	ea	38.5x15.75 Upper coner Window and frame
Win_Sm_C	8	ea	37.625 x 15.75 Cupola Window and frame
Win_Tri_A	6	ea	16- 1/8 x 34- 1/8 Glass for Triangles on Wings
Win_Tri_B	6	ea	15.25 x 32.25 Glass for Triangles on Main Building
Win_Roof_LA	6	ea	50- 1/16 x 39.25 <b>Safety or Tempered</b> Glass for Lower Wings Roof. Check Local code for required thickness.
Win_Roof_LB	6	ea	50- 1/8 x 37-5/8 <b>Safety</b> Glass for Lower Wings Roof
Win_Roof_MA	8	ea	57" x 47.5 <b>safety</b> Glass for Mid roof rectangles
Win_Roof_MB	8	ea	56 x 47.5 <b>Safety</b> Glass for Mid roof Triangles
Win_Roof_U	8	ea	56 x 47.5 <b>Safety</b> Glass for Cupola Roof

For single Pane Glass installed: \$6,000.00

\$6,255.00

Double price for Double pane Glass

Locating the Greenhouse



Sunlight

Assuming you live in the Northern Hemisphere, the ideal position for the greenhouse is where it will:

- get full sun in the winter when the sun is low in the south and
- get shade in the summer when the sun is overhead.

Where the house sits, how tall it is, and where trees are, should determine the location. The winter is critical and the less shade on the greenhouse the better.

## Locating the Greenhouse

-  **Poor location: Some shade almost all day**
-  **Good location: Some Shade either in the morning or the afternoon**
-  **Excellent location: Never in the shade**

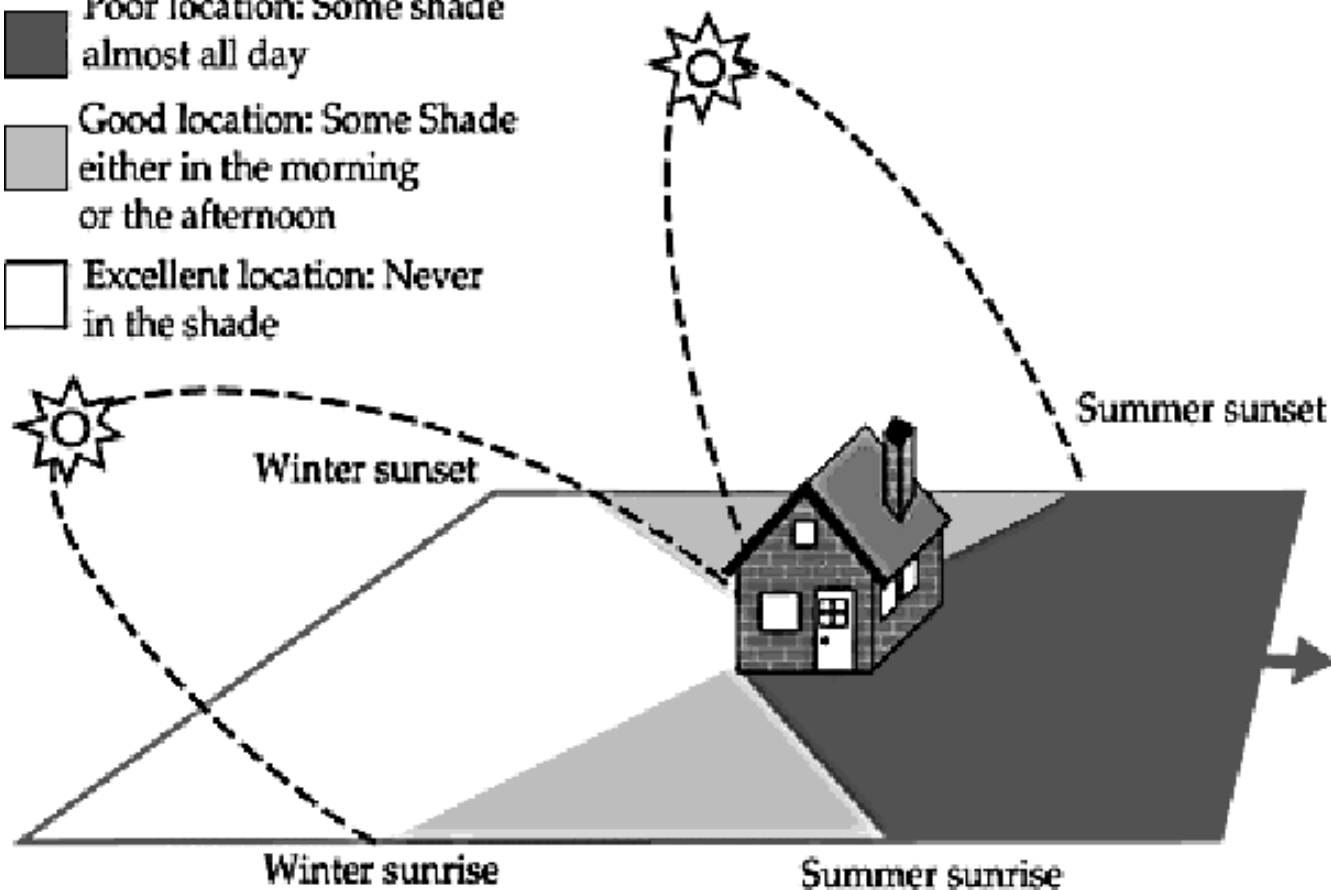

**Check where the shadows of fences, buildings, and trees will be cast by both the summer and winter sun. Locate the greenhouse where there is a minimum of shade.**

Illustration from "Charley's Greenhouse" <http://www.charleysgreenhouse.com/ch-site.html>

## Modifying the Design to Fit your Needs

There are many reasons why you may want (or need) to change the design:

1. Climate ;
2. Local Codes;
3. Attaching to an existing building; or
4. Using Different Materials.

### 1. Climate

*Warm Climates:* This greenhouse was built in a mild climate with short winters and an occasional freeze. We opted for no insulation and single pane glass. The raised slab is to prevent flooding due to regular torrential rains. Natural gas is readily available and relatively cheap and for as little as we need to heat the greenhouse, the low energy cost made the single pane glass very affordable and practical. However, with the long hot summers, the greenhouse turns into a kiln and we move all the plants out around the pool and walks. I am investigating building a hybrid evaporative cooler / air conditioner for summer use but I wont be able to trial the design for a year or two (the next century maybe!) See HVAC sketch in the plan packet.

*Cold Climates:* Double or triple insulated glass, insulation, and foundation modifications should be considered. Perhaps, the back wall, if on the north side, could be built into a hillside or attached to a shed / house to cut down on the glass and heat loss on the shaded side of the building. If this option is explored, drainage, aesthetics, and structural integrity must be carefully considered.

### 2. Local Building Codes

Since this is unoccupied space, some building codes may not apply. However, it's best to discuss the project with your local planning department (city or county) to determine if a permit is required and determine how far from the property line the building must sit. The "set back" requirements vary between cities, districts, counties, zones, and side, front or back property lines.

Gas piping and electrical wiring are two of the most dangerous aspects of the installation and improper installation could result in death or loss of property. An expert is often the safest way to go, although they can make mistakes, too. The purpose of the permit / building inspection is to help insure safety and good building technique.

## Attaching to an Existing Building

A fourth wing could easily be added to the design to provide a walkway between an existing building and the greenhouse.

Another option would be to cut the structure in half and attach it to a long flat wall.

A third option would be to wrap around /offset from the corner of your house.

An attached "sunroom" would probably count as square footage and, thus, add more to the "appraised" value to your home than a free standing greenhouse. In our recent appraisal, the conservatory, shed, brick patios, landscaping, etc. only added \$2,000 to \$5000 to the value of the home. The pool only added \$3000. The single pane glass alone cost \$6000 installed. If you're looking at this project as an investment, don't. My *3D Home Architect* by Broderbund quotes two conflicting articles on the cost versus value of a greenhouse. According to the National Association of Realtors, the resale gain of a green house is 10% of it's cost:

A few years ago, this addition was more popular than it is today. In a cold climate, a greenhouse may serve as an energy-efficient sun space in winter, but warm-weather months make it very uncomfortable without air conditioning . . . \* Rate of return will vary depending upon locale and trends.

A Chicago-based magazine, *Remodeling Contractor*, estimated the resale gain of a greenhouse at 89% of it's cost. My experience says 10% according to the appraiser. If I ever move, I'll give the purchaser the option to buy it for replacement cost. If not, I'm disassembling it and taking it with me! They can use the concrete pad for a gazebo. It was too much work and cost to give away to a stranger.

## Using Different Materials

Cypress, treated lumber, redwood, cedar, aluminum, or coated steel would all make adequate materials for the frame/trim work.

**Cypress** was the most economical because I had an available source\*. However, it was rough cut and had to be run through a joiner. This was heavy work for two semi-fit adults. Un-dried cypress is very heavy and likes to hold water. It shrinks a lot in it's width as it dries but not much in length. Let it season for a summer or two before installing glass!

**Treated lumber** is the most readily available but will probably bow and twist as it dries. You may want to let it the frame season for the summer before painting and installing glass.

I would be afraid to price **redwood** and then it would be a shame to paint it white. I don't know if you can get big **cedar** beams for the frame. **Aluminum or steel construction** would be expensive but there are a few companies that do beautiful work with these materials. The resulting greenhouse would probably last a lifetime (or two). A welded structure out of 4" square tubing could be quite spectacular.

\*Source for rough cut cypress: Frank's Sawmill, 531 Oilwell Road, Ovet, MS, 39464..

## 2. Pouring the Foundation

A raised slab (in parts of the south, people bury their dead above ground because of the high water table). You may not need the full 12" . . .



Layout

Start with the 16' back wall and plant two stakes equal distance from the property line or fence. Allow 1 ½" for the form board if using 2x12s for the frame. The setback in my back yard had to be at least 5 feet so the stakes had to be a minimum of 4'10 ½" from the property line. Some areas require 10 feet or more. Be sure and check your local building codes.

1. Position a straight 16' treated 2x12 between the stakes and make sure it's level. Before attaching it to the stakes, make sure the top of the stakes will be below the top edge of the board so they do not interfere with the screed.
2. To lay out the main room, 16' x 16', use batter boards and string lines. Measure diagonals to square-up. When diagonals are of equal length the room is square.

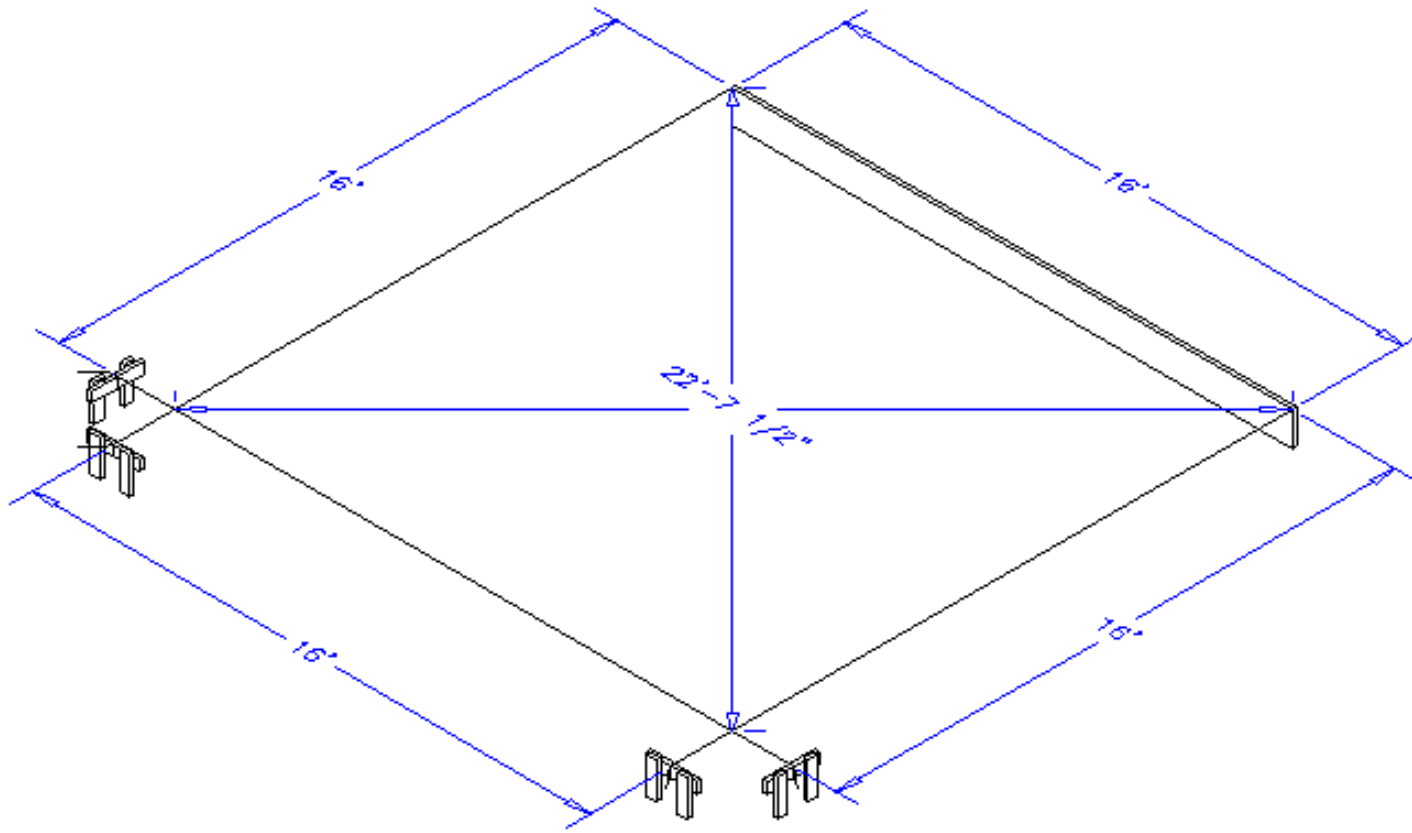

- 3.
4. Cut the rest of the boards:
  - (4) boards at 4'-1 1/2" long
  - (2) boards at 4' long
  - (6) boards at 7'-10 1/2"
  - (3) boards at 8'-3"
 and position them aligned with the string as shown.

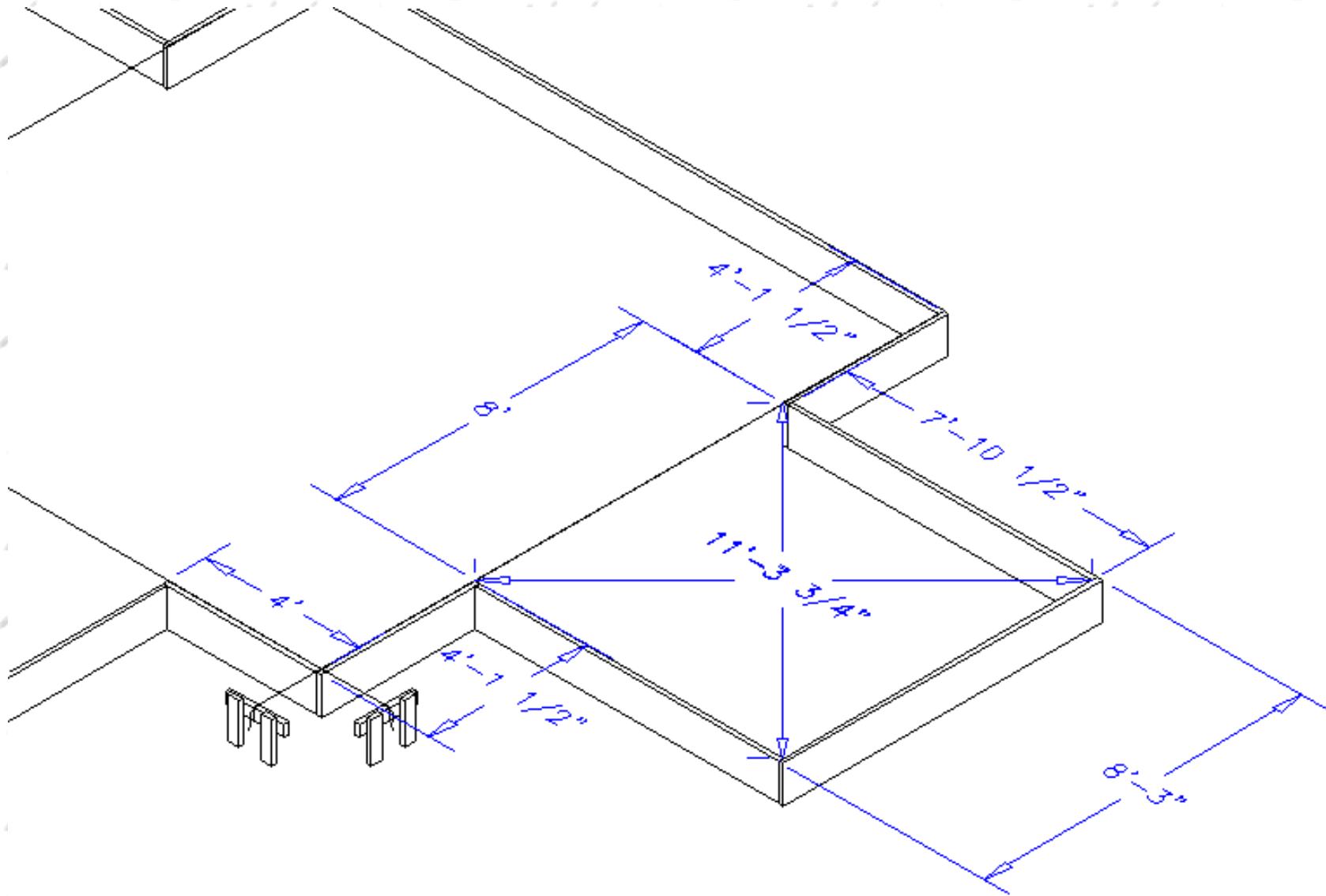

5. Place stakes with kick braces every 2' to 4'. Level forms starting in the back corner and working around the parameter. Nail boards to stakes.

6. Leave one of the 8'-3" long boards off so it's easy to get the wheelbarrow in and out of the greenhouse. Remove all sod and dig a trench around the parameter (inside of the forms) at least 8" deep. See cross section view (next page).

Forms: Framing The Foundation

RAISED SLAB FOUNDATION

2" of foam insulation req'd in warm climates (LOS ANGELES / TAMPA)  
 Call on concrete contractor for concrete details

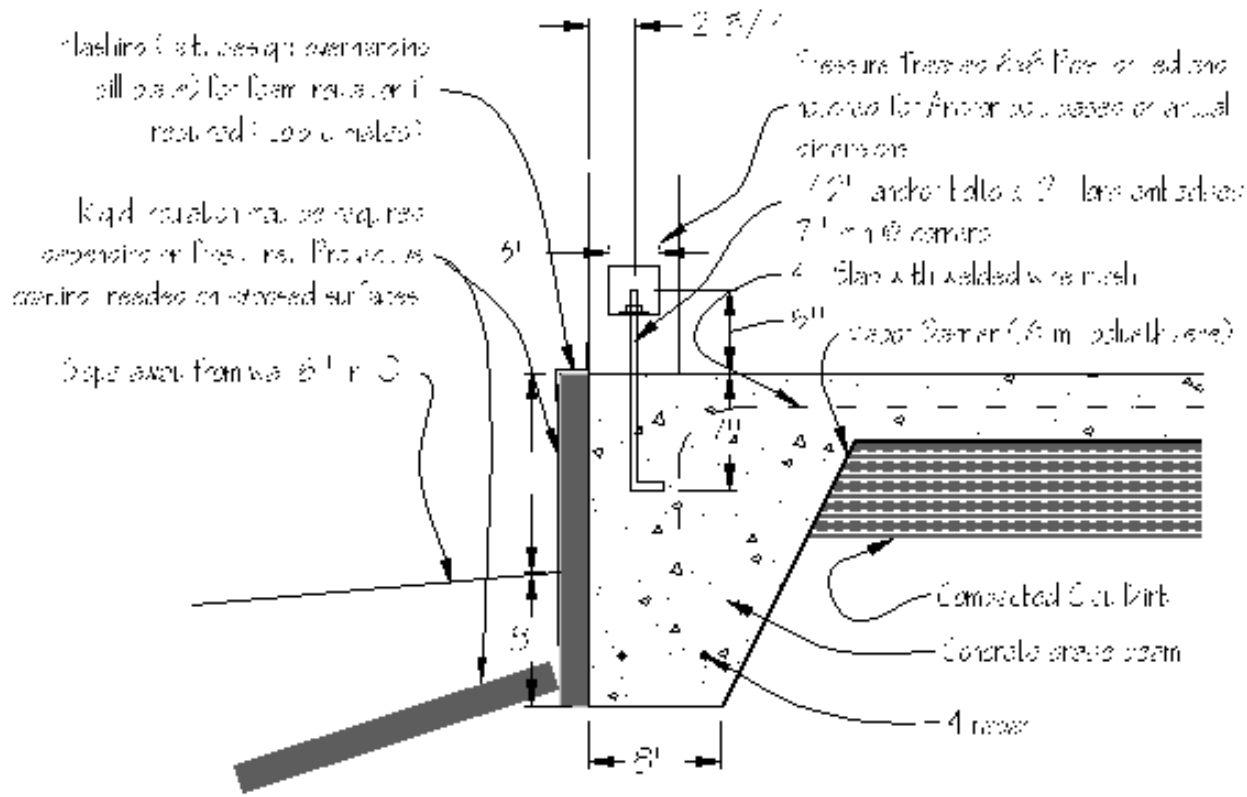

Cross Section of



concrete / trench.

## Roughing in the Plumbing & Electrical

1. Drain Piping: Put at least one drain per wing and slope pipe  $\frac{1}{4}$ " per foot. Run under framing. You may want to add a manufactured concrete catch basin at the end of the pipe and pipe overflow to a storm drain, pond or ditch.
2. Water, Gas and Electric: Underground or overhead? Up the outside or inside. I ran all utilities underground and came in through the interior wall in the back corner. I dropped a 4" pipe into the dirt inside the form that I poured concrete around. Eventually the pipes will be covered with cabinets. I recommend a 2" PVC conduit for the electrical and a separate pipe for the gas and water. Make sure pipes are at least 4-5.5" from the inside of the form to allow for the brick wall and at least 8" from corners to allow for corner post timbers.

## The Pour

1. Fill dirt: use clay dirt or crushed rock to fill the center of form to 4"-5" below the level of the concrete. Use a compactor to compress dirt. Clean up trenches around the parameter.  
To calculate cubic yards take the area in square feet times the depth in feet and divide by 27.  $[(3 \text{ rooms} * 7\text{ft} \times 7\text{ft} \times \frac{1}{3} \text{ft}) + (15 \text{ft} \times 15 \text{ft} \times \frac{1}{3} \text{ft})] / 27 \text{ cubic ft/ cubic yard} = 4.59 \text{ cubic yards}$
2. Treat soil with termite chemical if desired or required.
3. Plastic sheeting: Cover soil and trenches with 6 mil polyethylene plastic sheeting.
4. Re-bar: Place 2 pieces of #4 re-bar in the trench 2-3" from bottom around the parameter of the form. Use wire to tie together and support on rocks.
5. Wire Mesh: lay welded wire mesh over the entire surface curving edges into trench.
6. Calculate the amount of concrete: Check ditch dimensions and floor depth. Here's the math:  
Floor:  $(3 \text{ rooms} \times 8' \times 8' + 16' \times 16') \times 4"/12"/\text{ft thick} / 27 \text{ cu.ft/cu.yd}$   
= 5.53 cubic yards.  
Integral Beam:  $16" \text{ deep} \times 10" \text{ wide} \times (16' + 6*8' + 6*4') / 144 \text{ sq.in/sq.ft.} / 27$   
= 3.62 cubic yards.  
Total:  $5.53 + 3.62 = 9.1 \text{ cubic yards}$   
Adjust numbers to actual dimensions and order a little extra concrete, just in case.
7. Invite lots of friends over to help spread concrete. Pour in sections separating the wings with a 2x4 and dividing the main room into quadrants with 2 x 4. Pour wings first. Remove 2x4 dividers as the concrete sets up being sure to fill in gaps..
8. Don't Forget to Put the **Anchor bolts** in before the cement gets too hard. One in each corner and two on back wall 2-3/4 inches from the edge.

## 3. Framing



## The Main Room

Build the main room 16' x 16' room first.

1. Position the four 6x6x10' corner posts first. Measure the height and position of the anchor bolt. Cut 2" tall by 3" wide by approximately 3.5" deep notch in post 1" higher than the top of the bolt. **Caution:** make sure when you tighten down the nut that you have thread remaining. Drill a ½" hole from base through notch. Soak the bottom 18" in wood preservative. Position notch to face inside instead of outside if possible. Using a long level to check plumb, brace the post in two directions (90° apart) with long boards and stakes in the dirt. Add remaining 7 posts & Brace.
2. Notch ends of 6x6x16' sill beams. Carefully place on top of the posts and temporarily tack in place with duplex nails. Drill 3/8" diameter holes 12" deep and counter bore ½" through both sill plates; secure with ½" x 12" galvanized lag screws with washers.
3. Install (4) diagonal tie bars. Use galvanized or stainless bar 4 x 1½ x 6'9" with a 5/8" diameter hole drill in the center of the bar 1" from the end. Drill 3/8" hole 5' deep in line with each hole. Secure bar with ½" x 5" lag screw and washer.

4. Check for plumb and level and adjust.
5. Tack temporary diagonal 2 x 4 corner braces on the interior.

## The Side Rooms

Repeat the following steps for each room

1. Position the two 6x6x8' corner posts first. Measure the height and position of the anchor bolt. Cut 2" tall by 3" wide by approximately 3.5" deep notch in post 1" higher than the top of the bolt. **Caution:** make sure when you tighten down nut that you have thread remaining. Drill a ½" hole from base through notch. Soak the bottom 18" in wood preservative. Position notch to face inside instead of outside if possible. Using a long level, brace the post in two directions making sure it's plum.
2. Nail a temporary support blocks to the 10' posts with their top surfaces level at a height of 8' from the floor.
3. Notch ends of 4x6x8' seal beams as shown. Carefully place on top of the posts and temporarily tack in place with duplex nails. Drill 3/8 diameter holes 12 " deep and counter bore ½" through seal plate; secure with (2) ½ x8" galvanized lag screws and washers.
4. Install (2) diagonal tie bars. Use galvanized or stainless bar ¼ x 1½ x27½" with a 5/8" diameter hole drill in the center of the bar 1" from the end. Drill 3/8 hole 3' deep in line with each hole. Secure bar with ½ x3" lag screw and washer.
5. Cut all rafter parts. Position ridge with 4 rafters, front and back and ridge support. Nail into place with galvanized framing nails.
6. Add remaining rafters.

Repeat the remaining side rooms.

## The Mid Joists

Now for the tricky part . . . the coffered ceiling of the main room.

**SAFETY NOTE:** Make sure the frame is securely braced and fastened before you start the roof. The diagonal tie bars must be installed and the side rooms assembled with cross bracing. Cross bracing also needed on the back wall until arch and plywood are in place. Also, you will be working in the air, 10' off the ground. Use scaffolding, tie lines and safety harnesses to reduce risk of injury.

1. Build temporary platform to support ridge beams and workers out of 2x12's, 4x4 support posts, and plywood.
2. Build ridge box out of 2x8s, support on posts at the proper elevation and position.
3. Add support joists and adjust as necessary. Fasten all joists and install top plates.

## The Cupola

1. Fasten sill to ridge box.
2. Screw 6x6 blocks to the sill with 8" lag screws by drilling 3/8" holes up from the bottom and counter boring 1/2". Shim as necessary to make plumb and tighten down.
3. Install top plates, center divider and diagonally brace for stability. Install (4) diagonal tie bars. Use galvanized or stainless bar 1/4 x 1 1/2 x 27 1/2" with a 5/8" diameter hole drill in the center of the bar 1" from the end. Drill 3/8 hole 3" deep in line with each hole. Secure bar with 1/2 x 3" lag screw and washer.
4. Build temporary platform and support key in center at proper height. Cut all rafters and center key.
5. Install corner rafters, nail and remove supports.
6. Install last four rafters.

## The Brick

Brick is not difficult with practice; just a little tedious.

1. Lay out the brick between the posts with approximately 3/8 inch between the brick. Adjust the gap as necessary to finish with a whole or half brick.
2. Make a story pole – a thin stick with evenly spaced lines marking the height of each course of brick. The top line should be at 34" from the bottom.
3. Mix a small batch of mortar. 3 parts sand and 1 part mortar cement. The mortar should be the consistency of whipped cream. Not runny and not dry. Set the first two bricks, one at each end, laying down a 1-inch-thick bed for each. Check for level in both directions, tapping gently with the handle of your trowel to make adjustments. String a mason's line to mark the level of the first course of bricks. Hold the line in place with bricks.
4. Build the lead – the beginning point for your courses. This is six courses high with each course half of a brick shorter than the one below it, (Remember that a brick is half as wide as it is long.) Level and plumb each course, and use a story pole to check for height. Lay down mortar and add the first course. Butter the end of each brick where it abuts another. Add the mortar by making a swiping motion along all four edges of each face.
5. Duplicate the lead on the other end of the wall. String a mason's line as a course guide, using line blocks to hold the line flush with the face of the bricks. Using the line as a guide, fill in each course, remembering to throw, furrow and butter. Cut bricks by first scoring a line around the brick. Thin crack the brick using a mallet and a brickset.
6. Continually adjust for level and straight courses, tapping gently with a mallet and 2x4. As you proceed, scrape off excess mortar with your trowel, taking care not to smear the bricks. Every so often, press the mortar with your thumb. If it feels firm and your thumb impression does not change shape, the joints can be finished.
7. Using a pointing tool, first smooth out the vertical joints, then the horizontal. Gently brush away excess as you work. Wash any smeared spots carefully with a damp rag -- once the mortar has set, it will be difficult to remove.

## The Lower Sill / Vertical Dividers / Horizontal Dividers.

Cut the sills to length and position them with the tops 36" from the floor and level.

1. Fill in the gap above brick with mortar.
2. Position 2 x 6 vertical dividers between each sill and top plate in the center of each 8 foot wing. Toe nail in place with 16 d galvanized finishing nails.
3. Position 4 x 6 horizontal divider in the corner window of the main room with it's lower edge at the same height of the wing top plate. Toe nail in place with 16 d galvanized finishing nails.

## 4. Electrical / Plumbing / Glass / Lighting / HVAC

### Electrical

The electrical must be run before the glass is installed. Use underground / outdoor rated 12-2 with ground wire for fan, lights and outlets.

1. Drill ½ holes in the bottom of rafters and through top plates.
2. Pull wire through holes.
3. Make sure any outlets are GFI protected (Ground fault interrupted).

### Plumbing

Run at least a ¾ inch water pipe into the greenhouse and add a spigot for a water hose.

### Painting

Use a stain approved for cypress, treated wood, redwood or cedar. Install window stops before painting and paint the window trim before installing.

### Glassing the Roof

Have stop blocks cut to keep the glass from sliding off the roof. Lay the glass in place to check fit. Remove. Apply bead of silicone sealant and lay the glass

in place. Secure with strips of cypress. Apply silicone and screw into place. Remove stop blocks when glue is dry. The roof must be safety glass or tempered. Tempered cannot be cut and must be ordered to size.

## Attaching the Spire

Build a platform out of sturdy  $\frac{3}{4}$  inch plywood and a 2x12. Make sure the plywood is securely fastened in the frame with duplex nails or screws. Slide 2x12 in place and securely fasten. Pre-assemble spire base and cover. Screw in base. Screw in place cover and seal with silicone sealant. Attach spire to base with stainless wood screws.

## Windows Galore

Most of the windows are fixed pane and are installed as shown in the drawings provided.

The smaller windows in the cupola and in the main room are designed to be opened inwards.

For automatic window openers, see Charley's Greenhouses and Indoor Growing Supplies: <http://www.charleysgreenhouse.com>. Modify the window design to top hinge and opening outward. Attach bracket.

## Entry Door

The entry door is framed with fir 2x4s that are securely screwed in place. Size for two standard of the shelf exterior French doors. Use door stops and solid brass hardware.

## HVAC

Make sure the ceiling fan is rated for outdoor duty.

The back wall was made out of plywood for easy installation of dampers. In summer, draw outside air in through the misting chamber. Chill the water for air conditioning. In winter, re-circulate air pulling warm air down from the top. If you want to run the mister, heat the water. Water treatment chemicals will be needed to prevent algae growth.

## 5. Furnishings / Growing Hints / Resources

### Accessories

I just started building benches, tables and shelves. Updates may be available at a later date.

### Growing Hints

See Ortho Books "Greenhouses". Order toll free 1-800-822-6349. Ortho Books, 1160 Research Blvd., St. Louis, MO 63132.

### Resources

Greenhouse supplies and information abound on the web. Two that I've found so far that look interesting are:

- Sherry's Greenhouse, <http://www.teleport.com/~earth/index.shtml>; and
- Charley's Greenhouse Supplies, 1599 Memorial Highway, Mount Vernon, WA 98273. 1-800-322-4707. [Http://www.charleysgreenhouse.com](http://www.charleysgreenhouse.com).

For plants, our favorite catalogs are listed below:

- Logees Greenhouses, 141 North Street, Danielson Connecticut, 06239-1939, [www.logees.com](http://www.logees.com). 888-330-8038
- Southern Perinials and Herbs, 98 Bridges Road, Tylertown, MS 39667-9338. <http://www.s-p-h.com/>. 800-774-0079
- Thompson and Morgan seed, PO Box 1308, Jackson, NJ 08527-0308 800-274-7333,
- Wayside Gardens, 1 Garden Lane, Hodges, South Carolina, 29695-0001 800-845-1124, and
- Spring Hill. 6523 N. Galena Rd., Peoria, IL 61632, 800-582-8527
- Park Seed, 1 Parkton Ave, Greenwood SC 29647-000, <http://www.parkseed.com>, 800-845-3369.
- I'm into Thai food and Glasshouse Works was the only place I could find a Kaffir Lime Tree. Church Street, Stewart, OH 45778-0097, 1-740-662-2142,

800-837-2142, <http://www.rareplants.com> or <http://www.glasshouseworks.com>.

Have fun!

For information, e-mail or write:

Joe Zeeben, 816 E. Laurel Ave., Hattiesburg, MS 39401, [jozeeben@netdoor.com](mailto:jozeeben@netdoor.com),



[\[h2ome\]](#) [\[Plans\]](#) [\[Supplies\]](#) [\[Kits\]](#) [\[Books\]](#) [\[Links\]](#) [\[Orders\]](#) [\[More!\]](#)

Copyright 1998 H2OHOUSE, Inc. All rights reserved.



Please contact our Webmaster with questions or comments.